

# PennyPincher Pallet™

CORRUGATED PALLETS THAT WILL CHANGE THE WAY YOU SHIP.

[www.pennypincherpallet.com](http://www.pennypincherpallet.com)



# TABLE OF CONTENTS



2. **About St. Marys Box Co.**
4. **Practicality**
6. **Customizing**
8. **Freight & Shipping**
10. **Safety & The Environment**
12. **History & Physics**
14. **Key Points**

## ABOUT ST. MARYS BOX CO.

For more than 45 years, St. Marys Box Company has been manufacturing a full line of corrugated products. We are a full-service, quality corrugated supplier providing our customers with a complete line of products and applications. St. Marys Box Co. is a family owned corrugated business and has been since our start in 1955 as a sheet plant.

Our policy is to provide 100% Customer Satisfaction and 100% On-Time Deliveries. We strive to develop long term business relationships based upon an understanding of mutual honesty and integrity. A Quality Assurance program is performed in house. Keeping in line with our product quality, only the best materials are used in the production of our products. Throughout the entire manufacturing process a team concept is employed, whereby the crews assume total responsibility for product quality.

Corrugated is extremely durable, versatile, and lightweight, as well as innovative. We manufacture shipping containers, packaging material, store displays and are able to meet or exceed any of your custom corrugated needs.



**St. Marys Box Company Inc.**  
**South St. Marys St.**  
**P.O. Box 910**  
**St. Marys, PA 15857**

Phone: (814) 834-3819 • Fax: (814) 781-1964  
[www.stmarysbox.com](http://www.stmarysbox.com) • [www.pennypincherpallet.com](http://www.pennypincherpallet.com)  
E-mail: [service@stmarysbox.com](mailto:service@stmarysbox.com)

# PRACTICAL

The standard 48" x 40" PennyPincher Pallet™ weighs only 9 lbs (may be customized)

- ⦿ Static load tested to over 10,000 lbs<sup>1</sup>
- ⦿ Durable, Strong, Reusable and Recyclable
- ⦿ Reduces downtime, wear & tear on Auto-Palletizing equipment
- ⦿ Absorbs the weight of the load reducing damage to your product
- ⦿ 100% coverage of top deck

Multi-Tier Stacking ▼



10,000 lb. Static Load Test ▲

The PennyPincher Pallet™ is practical in every way. The standard 48" x 40" pallet weighs approximately ten to eleven pounds, and may be customized to your requirements. Since a PennyPincher pallet is less rigid than a wooden pallet, it will not damage expensive auto-palletizing equipment. The PennyPincher Pallet™ has 100% top deck coverage, so nothing will slip through the cracks.



1: This test does NOT reflect a shipping / transport environment.

# CUSTOMIZABLE AND VERSATILE



◀ Our 4-Way modification

- ⦿ Available in multiple sizes
- ⦿ Can be customized to your product's load, size and weight requirements
- ⦿ Reduces storage requirements
- ⦿ Options include, but are not limited to the following:
  - Overall Pallet Dimensions (length, width, height)
  - Runner Dimensions (width, number of runners)
  - Top and Bottom Deck Composition
  - 4-Way Entry
    - Floor Jack Holes
  - Banding Slots
    - Load Stabilizer
  - Coatings:
    - Anti-Skid, Paraffin Wax, Color Coatings,
    - Greaseproof Resistant Coatings, Volatile Corrosive Inhibitors (VCIs)

We would like the PennyPincher Pallet™ to be your primary pallet. That is why we have designed it to be versatile and customizable. At 3.5 inches high, the PennyPincher Pallet™ reduces your storage area for pallets. The pallet can be customized to your product's size or weight, by adjusting the deck materials. The runners can be modified for 4-way access, and banding slots can be added. Floor jack holes are also an option, making this pallet customizable to any application. The clean lines of the pallet make it a perfect fit for Point-of-Purchase Displays.

▼ Clean appearance



# FREIGHT AND SHIPPING

- ◎ The PennyPincher Pallet's lightweight characteristics will help reduce shipping cost
- ◎ A 48' trailer holds 28 Standard Pallets,
  - 28 PennyPincher Pallets™ - 252 lbs
  - 28 Wooden Pallets - 1120 lbs<sup>1</sup>
- ◎ Reduces fuel consumption in shipping
- ◎ Exempt from many export regulations<sup>2</sup>
- ◎ Custom sizes mean increased shipping capabilities and quantities

▼ Pallets ready for shipment



Since October of 2001, many overseas countries, in addition to the European Union have enacted regulations impacting the use of non-manufactured wood packing materials. These regulations are designed to control the spread of foreign insects. Corrugated pallets have an obvious advantage when it comes to these wood-borne pests. The pallets do not provide a habitat or food source for pests that eat or burrow into wood. As such, they do not require specialized treatment for export.



Because corrugated has cushioning properties, the pallet itself minimizes transit vibration, which reduces damage to your product. When it comes to shipping, the PennyPincher Pallet™ is a lightweight champion. Since our pallet is corrugated, when shipping internationally, it is exempt from the IPPC, RESY, the European Union<sup>2</sup> and many other export regulations that pertain to non-manufactured coniferous wood packing material.

1: Based on a standard 40 lb. pallet

2: The European Union's requirements apply to "non-manufactured coniferous wood packing material" [Commission Decision of 12 March 2001 (2001/219/EC), L 81/39-40]

# SAFETY AND ENVIRONMENT



Breaking down a PennyPincher Pallet™ for recycling ▲

- There are no nails, splinters, broken boards or protrusions
- Safer handling characteristics for shippers and consumers
- Using a utility knife, a PennyPincher Pallet™ is easily disposed of in compactors & bailers
- Made from 100% corrugated paper, a material that recycles easily
- Reduces waste in landfills
- Reduces end-user disposal cost

The PennyPincher Pallet™ is a safe pallet, free from stray nails and broken boards. Just think, no more splinters. This pallet is safe for those on the factory floor and also those in the commercial market.

A report by the National Center for Environmental Decision-Making Research declared that 6.16 million tons of wood pallets entered municipal solid waste landfills or other landfill facilities in 1995. Another report claims wooden pallets represent 4% of all solid waste in landfills. Many landfills have actually stopped accepting pallets and other landfills charge fees for recycling them. The PennyPincher Pallet™ is made from 100% corrugated materials, that is recycled easily.



# HISTORY AND PHYSICS



A loaded pallet prepared for shipping ▲

We have always attempted to be on the leading edge of developing new and innovative corrugated products. When our customers' requested an improved pallet, we developed the PennyPincher Pallet.™ Our first corrugated pallet was developed in 1997. Since then, it has gone through five major revisions to the superior final product. These corrugated pallets are designed and developed by our internal specialists here at the St. Marys Box Company, who have 115 years of combined experience.

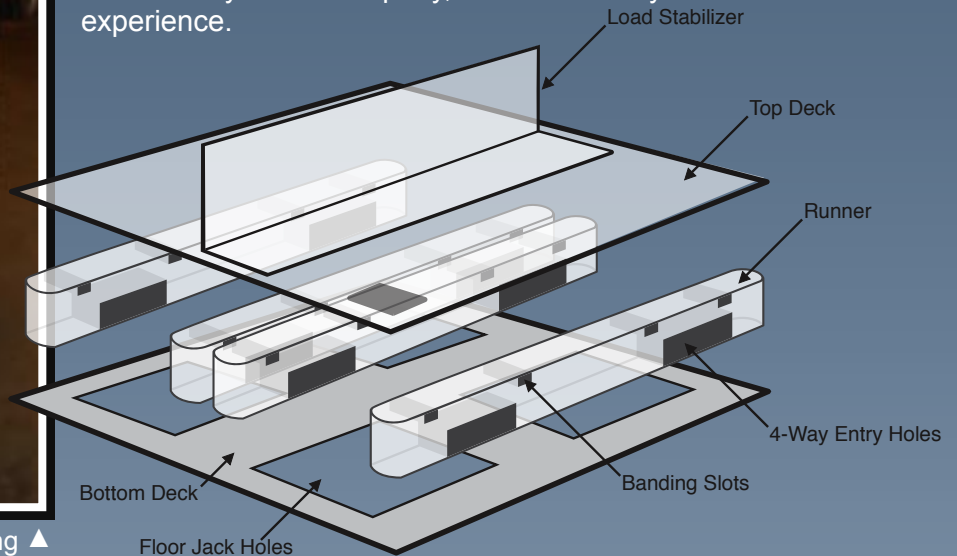

The strength of our corrugated pallet is deceptively simple. A cylinder has no weak points in its design, while a cube by basic design has 8 weak points (the eight corners of the cube). In one standard runner, there are over 1,500 cylinders (corrugated flutes). With over 6,200 individual cylinders, you can see why a standard four-runner pallet can easily bolster a 10,000 lb. static load test.<sup>1</sup> And since corrugated materials have cushioning properties, the PennyPincher Pallet™ actually minimizes transit vibration and other shocks that are incurred during shipping.

## ▼ Our patented runners



1: This test does NOT reflect a shipping / transport environment.

# OVERVIEW AND KEYPOINTS

## Practical

- ⊙ The standard 48" x 40" PennyPincher Pallet™ weighs only 9 lbs (*may be customized*)
- ⊙ Static load tested to over 10,000 lbs<sup>1</sup>
- ⊙ Durable, Strong, Reusable and Recyclable
- ⊙ Reduces downtime, wear and tear on Auto Palletizing equipment
- ⊙ Absorbs the weight of the load reducing damage to your product
- ⊙ 100% coverage of top deck

The PennyPincher Pallet™ is practical in every way. The standard 48" x 40" pallet weighs approximately ten to eleven pounds, and may be customized to your requirements. Since a PennyPincher pallet is less rigid than a wooden pallet, it will not damage expensive auto-palletizing equipment. The PennyPincher Pallet™ has 100% top deck coverage, so nothing will slip through the cracks.

## Customizable & Versatile

- ⊙ Available in multiple sizes
- ⊙ Can be customized to your product's load, size and weight
- ⊙ Reduces storage requirements
- ⊙ Options include but are not limited to the following: Overall Pallet Dimensions, Runner Dimensions, Top & Bottom Deck Composition, 4-Way Entry, Banding Slots, Floor Jack Holes, Load Stabilizer, and coatings.

We would like the PennyPincher Pallet™ to be your primary pallet. That is why we have designed it to be versatile and customizable. At 3.5 inches high, the PennyPincher Pallet™ reduces your storage area for pallets. The pallet can be customized to your product's size or weight, by adjusting the deck materials. The runners can be modified for 4-way access, and banding slots can be added. Floor jack holes are also an option, making this pallet customizable to any application. The clean lines of the pallet make it a perfect fit for Point-of-Purchase Displays.

## Freight & Shipping

- ⊙ The PennyPincher's lightweight characteristics will help reduce shipping cost
- ⊙ A 48' trailer holds 28 Standard Size pallets.
  - 28 PennyPincher Pallets™ = 252lbs
  - 28 Wooden Pallets = 1120 lbs<sup>2</sup>
- ⊙ Reduces fuel consumption in shipping
- ⊙ Exempt from many export regulations<sup>3</sup>
- ⊙ Custom sizes mean increased shipping capabilities and quantities.

Because corrugated has cushioning properties, the pallet itself minimizes transit vibration, which reduces damage to your product. When it comes to shipping, the PennyPincher Pallet™ is a lightweight champion. Since our pallet is corrugated, when shipping internationally, it is exempt from the IPPC, RESY, the European Union<sup>3</sup> and many other export regulations that pertain to non-manufactured coniferous wood packing material.

## Safety & Environment

- ⊙ There are no nails, splinters, broken boards or protrusions
- ⊙ Safer handling characteristics for shippers and consumers
- ⊙ Using a utility knife, a PennyPincher Pallet™ is easily disposed of in compactors & bailers
- ⊙ Made from 100% corrugated, recyclable and re-pulpable
- ⊙ Reduces waste in landfills
- ⊙ Reduces end-users disposal cost

The PennyPincher Pallet™ is a safe pallet, free from stray nails and broken boards. Just think, no more splinters. This pallet is safe for those on the factory floor and also those in the commercial market. Many landfills have actually stopped accepting pallets and other landfills charge fees for recycling them. The PennyPincher Pallet™ is made from 100% corrugated materials, that is recycled easily.

## History & Physics

We have always attempted to be on the leading edge of developing new and innovative corrugated products. When our customers' requested an improved pallet, we developed the PennyPincher Pallet™. Our first corrugated pallet was developed in 1997. Since then, it has gone through five major revisions to the superior final product. These corrugated pallets are designed and developed by our internal specialists here at the St. Marys Box Company, who have 115 years of combined experience.

The strength of our corrugated pallet is deceptively simple. A cylinder has no weak points in its design, while a cube by basic design has 8 weak points (the eight corners of the cube). In one standard runner, there are over 1,500 cylinders (corrugated flutes). With over 6,200 individual cylinders, you can see why a standard four-runner pallet can easily bolster a 10,000 lb. static load test.<sup>1</sup> And since corrugated materials have cushioning properties, the PennyPincher Pallet™ actually minimizes transit vibration and other shocks that are incurred during shipping.

1: This test does NOT reflect a shipping / transport environment.

2: Based on a standard 40 lb. pallet

3: The European Union's requirements apply to "non-manufactured coniferous wood packing material" [Commission Decision of 12 March 2001 (2001/219/EC), L 81/39-40]

Note: PennyPincher Pallets™ are custom made to fit a specific product, to be placed on them under suitable conditions. St. Marys Box Company Inc. will not be liable for damages arising out of misuse or non-intended use. See our sales department to discuss customization for your product.



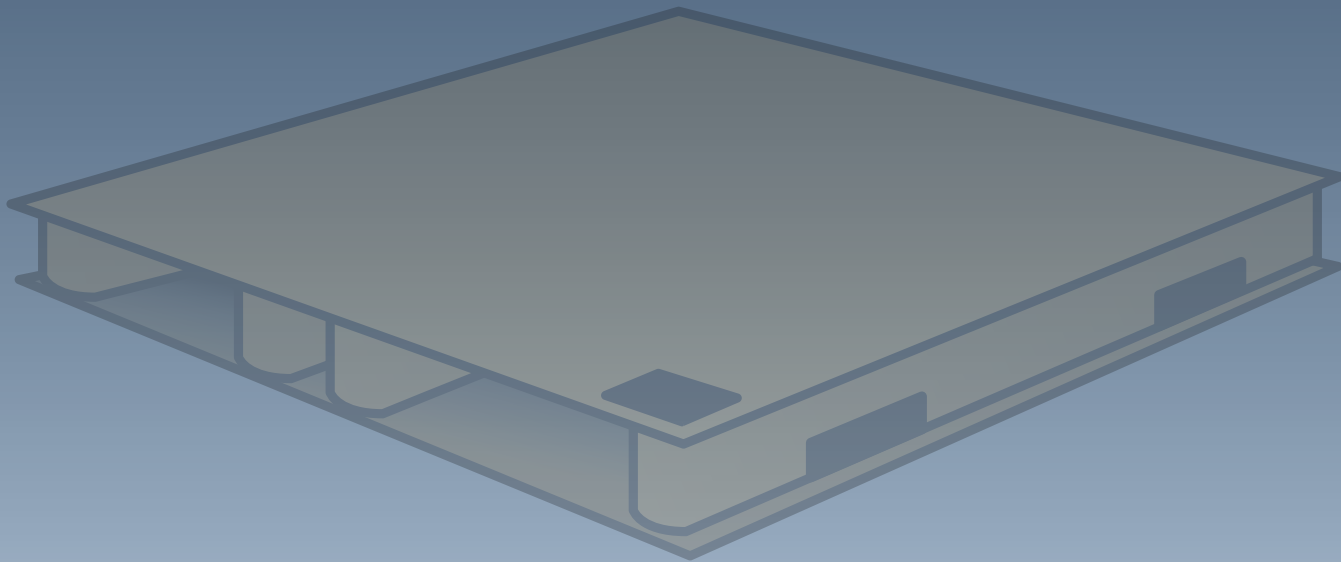

St. Marys Box Company - P.O. Box 910 - S. St. Marys Rd. - St. Marys, PA 15857  
ph: 814-834-3819 - fax: 814-781-1964 - [www.stmarysbox.com](http://www.stmarysbox.com) - [www.pennypincherpallet.com](http://www.pennypincherpallet.com)

